



MSC-49AN

Standard features include baskets, basket dividers, external thermometer and lock.

MB MASTER-BILT[®]

COLDIN-3™ SERIES

MSC-AN SERIES

Curved Lid Display Freezers

MODELS

- MSC-31AN
- MSC-41AN
- MSC-49AN
- MSC-66AN

FEATURES

CONSTRUCTION

- Standard interior LED lighting with separate on/off switch
- Curved tempered glass sliding lids
- White zinc-coated baked-on enamel steel exterior
- Painted white powder-coated steel interior
- Removable rubber bumper guards on grille side
- Heavy-duty casters, two locking
- Bottom drain with plug

- Lid lock and keys
- The unobtrusive frame around the glass lids ensures a highly visible display
- External analog thermometer display
- Control panel with adjustable temperature range of +10 to -18°F
- Low energy consumption

REFRIGERATION

- Refrigerant: R290
- Temperature range: -18° to 10°F (-27° to -12°C)

WARRANTY

- Standard limited one year parts and labor
- Additional four year coverage on compressor part

STANDARD BASKETS

MSC-AN models are supplied with equally-sized angled baskets and one adjustable horizontal divider per basket.

MODEL	NO. OF BASKETS/DIVIDERS
MSC-31AN	3/3
MSC-41AN	4/4
MSC-49AN	5/5
MSC-66AN	6/6

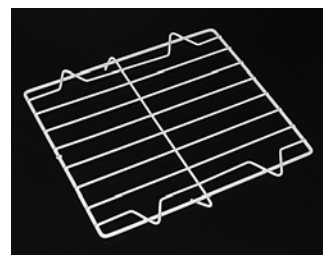
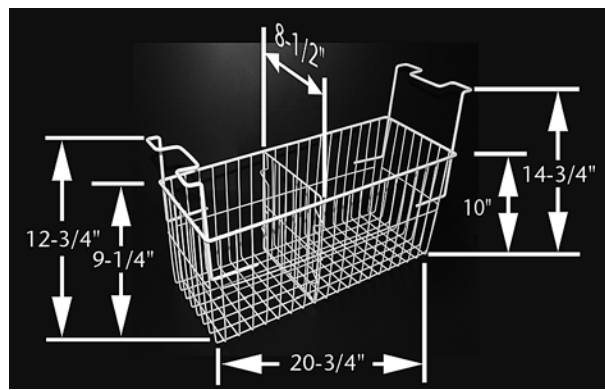

Horizontal divider



COLDIN-3™ MSC-AN SERIES CURVED LID DISPLAY FREEZERS

TECHNICAL SPECIFICATIONS

MODEL	DIMENSIONS (in.)			DIMENSIONS (mm)			VOLTS	AMPS	UNIT H.P.	GROSS CU. FT.	NET CU. FT.	SHIP CU. FT.	SHIP WT. LB/KG
	L	D	H	L	D	H							
MSC-31AN	31	27 ³ / ₈	33 ¹ / ₂	787	695	851	115	1.0	1/3	8.3	6.0	20.7	186/85
MSC-41AN	41	27 ³ / ₈	33 ¹ / ₂	1041	695	851	115	1.2	3/8	11.5	8.5	26.7	215/98
MSC-49AN	49	27 ³ / ₈	33 ¹ / ₂	1245	695	851	115	1.5	3/8	14.3	10.6	31.1	230/105
MSC-66AN	66 ¹ / ₂	27 ³ / ₈	33 ¹ / ₂	1676	695	851	115	2.8	3/4	20.3	15.1	42.1	285/130

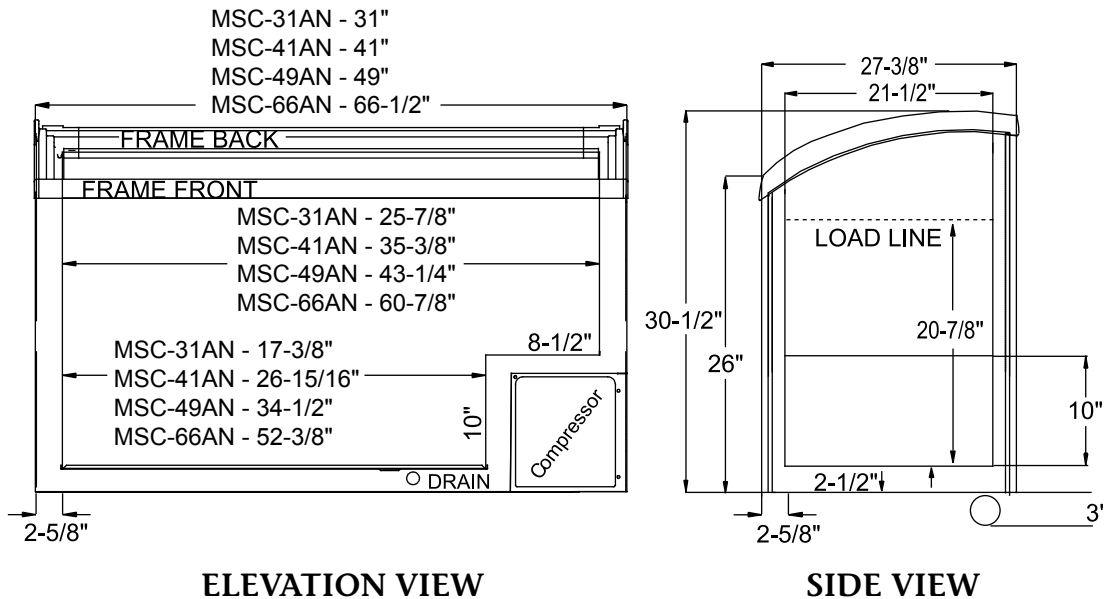

LISTINGS



HOOKUP

Via plug in, 6¹/₂ foot long, flexible 3 wire 14AWG/3 cord with molded plug.



BID SPECIFICATIONS

Item no. MSC-____AN
Provide _____ () Curved Lid Display Freezer(s) Master-Bilt® model MSC-____AN.
Freezer to be constructed of a white zinc-coated baked-on enamel on steel exterior with painted white powder-coated steel interior. Freezer to be furnished with stan-

ard LED interior lighting. Also standard with baskets, basket dividers, thermometer and lock. Additionally, it will be provided with heavy-duty casters and a defrost water drain. Lids will contain tempered safety glass.
Refrigeration system will use R290 refrigerant in all models. The temperature

range will be -18° to 10°F (-27° to -12°C).
Freezer to have standard limited one year parts and labor with additional four year coverage on compressor part.
Freezer to be ETL listed in the U.S. and Canada and ETL Sanitation listed.

NOTE: Cabinet designed for optimum performance in air-conditioned area at 75°F ambient and 55% relative humidity. All specifications subject to change without notice.



908 Highway 15 North • New Albany, MS 38652
PHONE: 800-647-1284 or 662-534-9061 • FAX: 800-232-3966 or 662-534-6049 • www.master-bilt.com